

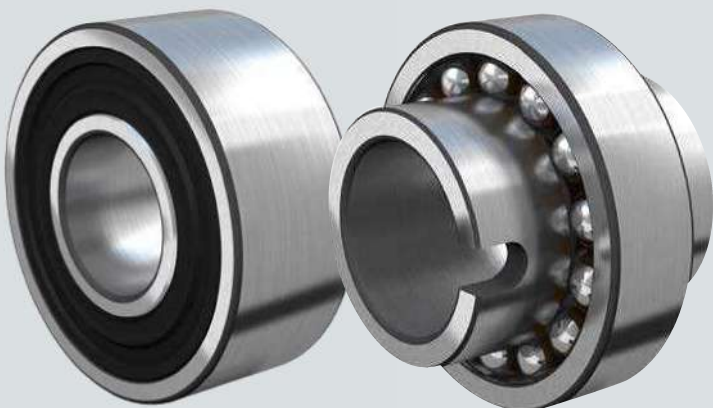

چرخ صنعت کشور

S, k c, $\frac{1}{2} S, k c, \frac{1}{2} S, k c, \frac{1}{2} S, k c, \frac{1}{2} S, k c,$
d S c t $\frac{1}{2} S, k c, \frac{1}{2} S, k c, \frac{1}{2} S, k c, \frac{1}{2} S, k c, \frac{1}{2} S, k c,$



Dmv nv MhT yM Mahv

nMmT f nM n v

Sc,Sh dSct3inv SFx3iqSh y 3WOCnæ:OavSc,v
Cn dCaW3iSv -R13 ctScLc3cd,S

t nN (sOrSs
(a \$R(LorO(N&KWOr(O(NO(WW
(a \$R(sOKV(WKNO(oF5ROO(stOO(rOsPbrMON
e Bi (-oS/KnN(a OKr8rOsStKnt/(NOs5nkt5n(
sl P#(8 i j ≤

gOrWss5V(Knhl Vr(WSK5nWOnt(oF5OKVON
LOKrs5hs(S55RtV(rON MONMWPkRON(to(
opOn(NO55n(LOKrs5hs1

kx F&tKneKre&ssort3 Pnt

Mu vS,k c,3m3mdc,, dSct3imLct3nav ctS

CqSn -R13

O y 3WOC,3iht3C, dCtS

O y 3WacqStSh dCtS S mKct xvSy 3W
chcqæSt v,SSLSv -R13

O y 3WszænhSh 3nSt t3im -R13

vSc,Sh -R13

O y 3WOC,3iht3C, dCtS

O y 3WacqStSh dCtS S mKct xvSy 3W
chcqæSt v,SSLSv

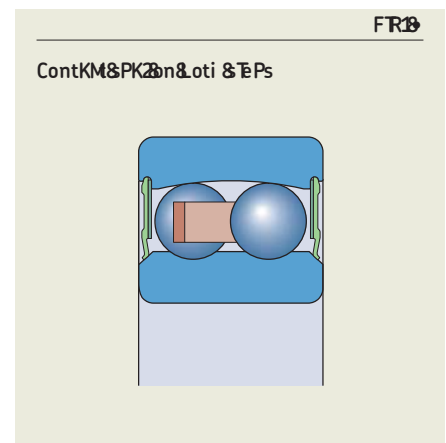

GrPKsPs&pr&MkppPe&LPkrTrRs

o Sct 3mv vSc, Sh Cn dCaW3h Sv ctS, x dt 3taSh
 Kct aVb, 3S CkaVb dSct 3mch ctSL3axc,,e
 - c3n3ncn05 ktS >Vbe ctk ..kSc (w Cnk CV
 wk Vc..Cc (nWudnSdsVWkduku c (h dLk
 WECShCscCu(n (n f(vnWqsCqksvku tKL28

D(O) (4(z k (hrOKsO
 (D°) (4(z k (hrOKsO

GrPKsP2TP&pr&MkppPe8 LPkrTrRs

(S(prOsOntONkS(y //SOItROtSVOpOrSnKt
 tROOnNoPa RSR(fl(oPrtROLOkrSihS(KrO
 stSvROSLV(V LrSkTON
 (NOpOnNs(on(tROopOrKtSih(tOWpOrKtl rO
 KnNtRO(nNyJKV Q-e KRrK3 8≤

kRO(hrOKsO(ROspOMSONS(e KRrK3 8(SJKVN
 POr(tROpVba Sih(MWLSihKtSih(oPopOrKtSih
 MnNSns,

(RorSiontKVsRKR
 (SnOr(rSh(rotKtSih
 (VhRt(vKN-g(O) / (C≤
 (opOrKtSih(tOWpOrKtl rOa \$RS(tRO(hrOOn
 tOWpOrKtl rO(donQ(oPrtRO(hrOKsO-tKL28≤
 (stKtSihKrc(WKMRSD
 (ba (JrKtSih(VJOV

v ROQ(tROopOrKtSih(MnNSns(NSPD/tRO
 hrOKsO(ROoLtkSON(ProW(tRONShrKW(sRol W
 LO(KNT stON,

(JortSKVSRKPs(4 (fl(oPrtROoLtkSONJKV O
 (ROKJSD(vKNs-g(° / (C44(KppV(rON M8
 tSih(PKMor-tKL28 ≤

v RO(nSOKVONLOkrSihS(WI st(opOrKtO) nNO
 MOrKtSih(ObrOWQ(MnNSns/(sl MR(KsJOrc
 RSR(spOONS(orRSR(tOWpOrKtl rOs/(hrOKsO
 WKc(KppOKr(on(tROMKppSih(NSWQO1For
 LOkrSih(KrrKnhOWonts(a ROQ(tRS(a ol WLO
 NOtrSVontKv(KppproprSktoKMns(sRol WLO
 tKl On1For(KNNNSnKvSihPvWktSih/(MntKM
 tROj xF(KppSkTSh(OnhSioOrSih(sORJSD1

PM mvm- M n n f M f nM n v

(KrO(KJKSLVO(Si(tRO (KnN (sOrSs
 (KrOQl \$pONa \$R(Kn(Knnl Vr(hrooJO(Si
 tROol tOr(rSh(KnN-R18 ≤
 O(tROOQl KW8spKMNV LrSkTSh(RoVos
 Si(tROol tOr(rSh
 O(sSiOQl KW8spKMNV LrSkTSh(RoVos(Si
 tRO(SinOr(rSh
 (MKnLOl sON(Si(Knc(KppSkTSh(a ROQVba
 P\$Sih(Si(proPronoJO(RSR(vKNMkrccSih
 MKpKMc-O1h1Si(tROpKpOr(SiN strcs

BnM n v c a Mh neannTmT nntt n

(KrO-R18, \$NOsInONP(vOss(NOWKnNSih
 KppSkTShs(trKtI sQ(MWVORMKnKNO
 sRKRSh
 (RKJO(KspOMKVLorQ(toVOrKnMO(MKssvj
 -tKL28≤(trKt(PKMSktOs(Wol ntSih(KnN
 NSWol ntSih
 (KrOvMktONKbKW(on(tROsRKR(Lc(WOKns
 oPksvotKt(onQOnNoPrtRO(SinOr(rSh(trKt
 OnhKhOs(KpS(orSrol VDR(sMOa (-R8 ≤
 -tONto(tROsRKR
 kRS(KvoprojOntS(tROsRKR(ProW(spSih
 nSih(Si(tROLOkrSih(LorO1

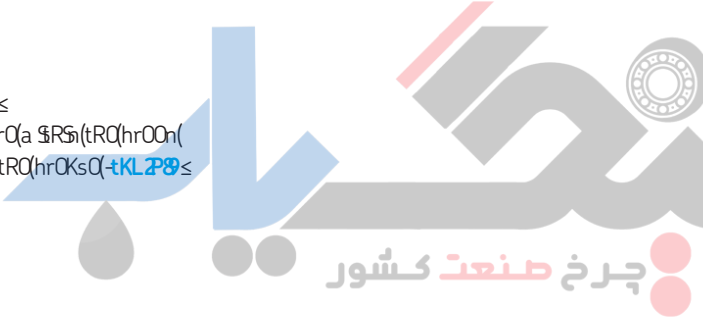

GrPKsP2TP&pr&StKneKre&MkppPe&P2y K2Rn TrR& K2L PKr TrRs & i PrP8 8 8 .208

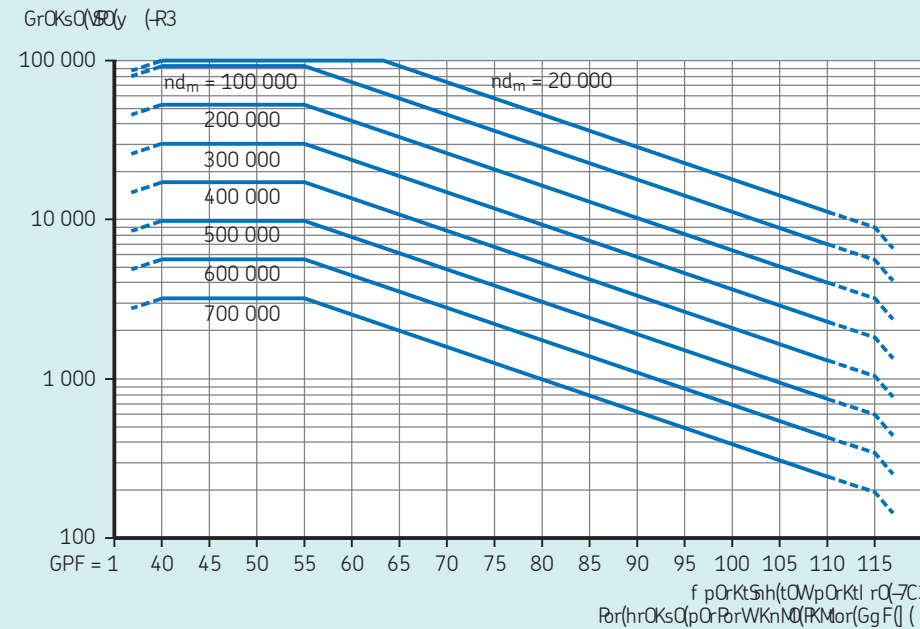

n() (rotKtSihKvSpOON-f2VSi3
 Nw) (LOkrSih(WOKn(NSWQO1-ww3
) / (-N, D≤

DKRrK3 8

6n0n7ne aF T TebDBaD- f v a teBl ell l ea a-Dl a e l a - e BB he h el B a

p el B Kl ea F leyl leB T B l pea D mi Kc lel pea D daTDa b5

Dybal 11 a

le bl hL p hL p

11 v v

p

G 084	4.		mL, 9M aChr	4 9(th0
r 884	4.		mL, 9M aChr	4 9(th0

v

i 3 3 >S3h) 30n, L3cn3rLrg96

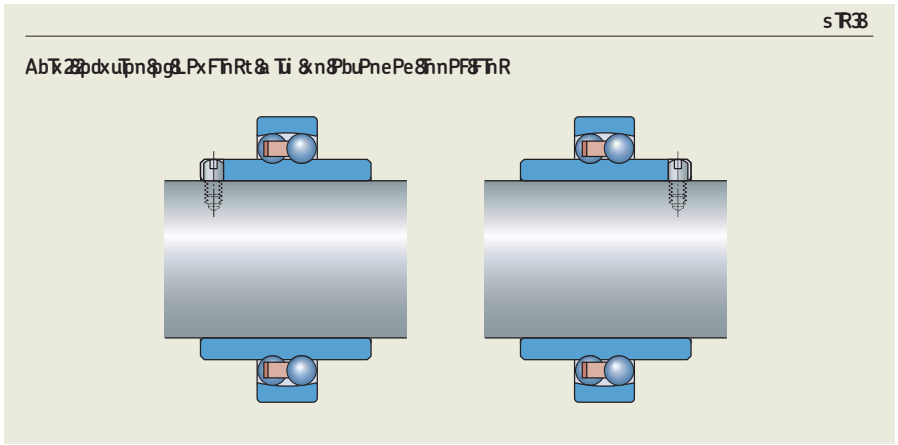
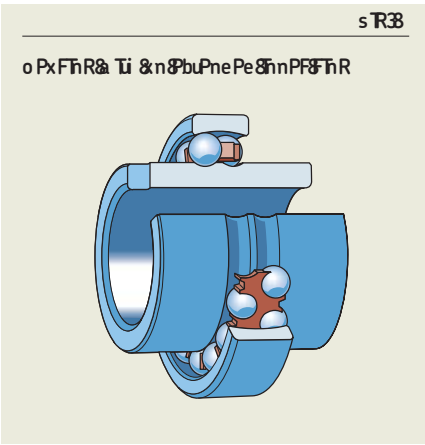
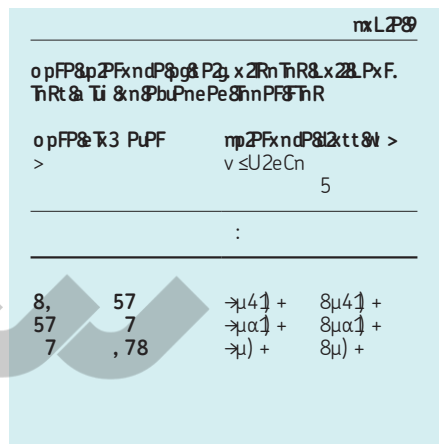
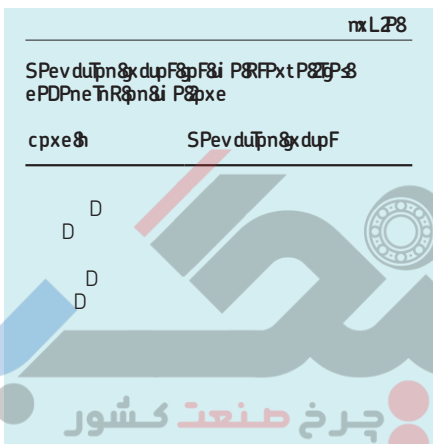
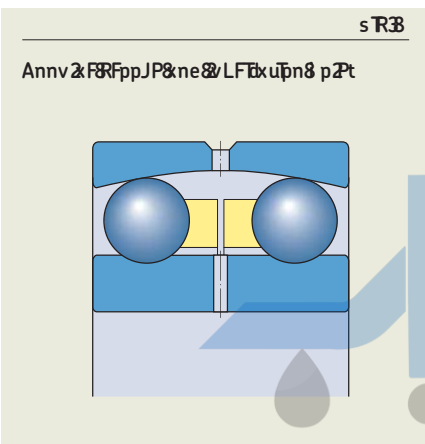

CKRP s & p r & P2/ K2Rn Tr R& K2L PKr Tr Rs

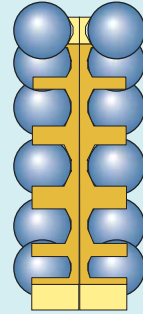
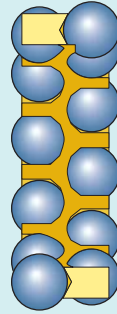
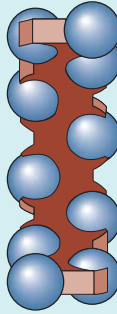
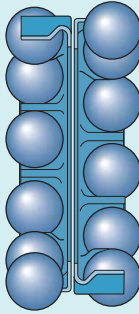
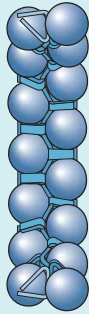

CKRP & cp P	l nk q(khk f.d.. hknvskS	, c C q(khk f.d.. hknvskS	l nk q(khk undq vqgk f.d.. hknvskS	l nk q(khk f.d.. hknvskS	, c C q(khk f.d.. hknvskS
d Kt Pr K2) vd qkS ukk.) vd qkS ukk.	mA -ff d d n rd	- n d-ff	- n d-ff
kl g-b				ot e ofigtoei (o g-fi+• ± : .+	0+ -Bp-gi u5nByl5pB+wlOM4 b 2i Bg-fi+• ± : .+

t p s e l i y s B n u b 9 2 B p B 7 u l y B g y s g e y n i u d e p B l y e l + c t 0



CM mv

r SqSnh3imCn aV53 vSt3v cnh v3S Mu vS,k c,3im3imdc,, dSct3imv ctk wkSc (w Cnk CVwk hdVkuu Cc n (n tKL P8 kn xukS dw (W vk qksdvksku uC k .xf s(hdnvu hdn dLk d Skv(knvd. kVKhwCn qC.gd (Sk hdVku t Cs dSS(vCnd. (nVcs dvCn df Cx vw k ux (vd f (.vg CVhdVku skVks vC pe 3w pKRP 41

hPr3 Ts L P8 n Rl 2r8 EK2Rn3 Pnt

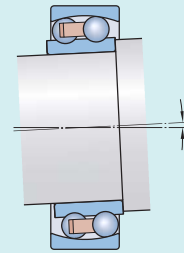

BPKr Tr Rs 3 Pr Ps	d EK2Rn3 Pnt
8	5

87 (.847.84=.84) .85	(
848E-	α1)
858E-	(
448E-	α1)
448E/4Sk8	μ1)
458E-	(
458E/4Sk8	μ1)
8848E-	α1)
857.85)	(

BmM n TMAM

<p>v Bd DB d0rB mc d</p>	<p>o CxnhtNg5 i Bu5Bu, a S+ • FMi El +ps,+ +oi ysBmu+ 52+yBi Mi Bgi g+BBi s+6Bm</p>
<p>D cnB d</p> <p>t ps+ygg55By> 5Blps: ylfB+ 1 +e5l</p>	<p>h ps: y> FMi El +ps, +oi ysBmu+ 52+yBi Mi Bgi g+BBi s+6Bm+ dpsi +p+pā syBei e>yuu+ +ve0l 1pKRP8 9. #ByeepsyBei b 52+y f (8 nkV Os,(y f ((-tKL2P8 /pKRP84<</p>
<p>vntPrnK2MPKrnMP</p> <p>For(KN55nKV 5rPrWkt5n(4 (pKRP84</p>	<p>e orWKV(C CROM(KJKSKLS5c(oPc (-M5N5SKV(LorQ(onV4 EbMpt(Por, (BOKr5hs5n(tRO((KnN(sOr5s,(C (BOKr5hs(a \$R(Kn(ObtOnNON5nOr(r5h,(rKh5h(PoW(tRO(W55VI W(JKV Q(oPc (to(tRO(WKb5VI W(JKV Q(oPc e orWKV nkV Os,(y f (8 (-tKL2P8 /pKRP8 4 nkV Os(KrQ(JK5N(Por(l nWol ntON(LOKr5hs(l nNOr(dOro(WOKsl r5h(bKNL</p>
<p>hPr3 5sL2P8 3 5K2Rn3 Pnt</p>	<p>GI \$NO5Q(JKV Os(Por(norWKV/opOrKt5h(MonN55n(-tKL2P84v ROtRO(tRO5Q(JKV Os(MKn(LQ(P W(Obp6\$ON(NOpOn5(on(tRO(NOs5n(oPcRO(KNKMOnt(MWponOnt5(/sl MR(Ks(ObtOrnKV5OKV1</p>

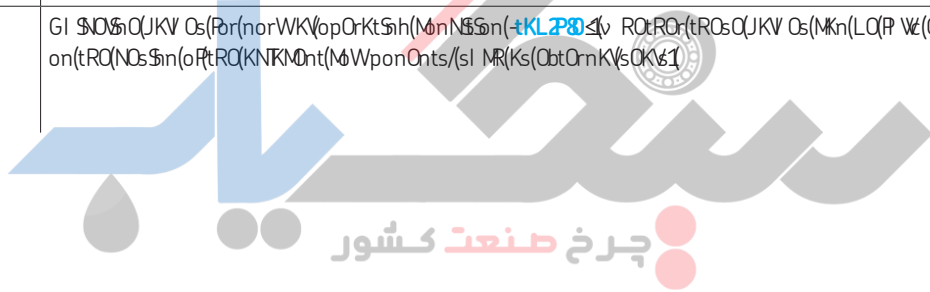

SKe K2RnTrR&K2L PKrTrRs

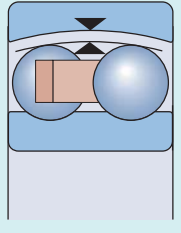

BPKrTrRs& Ti 8342herTK2lorP

BorP& K3 PtPr	SKe K2RnTrR&K2L PKrTrRs	D
h	D1 i Ct- c,	D
	o 9) o 9)	o 9)

BPKrTrRs& Ti 834KpPrPe&lorP8

BorP& K3 PtPr	SKe K2RnTrR&K2L PKrTrRs	D
h	D1 i Ct- c,	D
	o 9) o 9)	o 9)



- 4. 7
- 7 87
- 87 86

- 86 8(
- 8(46
- 46 57

- 57 67
- 67 7
- 7 7

- 7 (7
- (7 877
- 877 847

- 847 867
- 867 877
- 877 8(7

- 8(7 477
- 477 44
- 44 4 7

- 8(46
- 46 57
- 57 67

- 67 7
- 7 7
- 7 (7

- (7 877
- 877 847

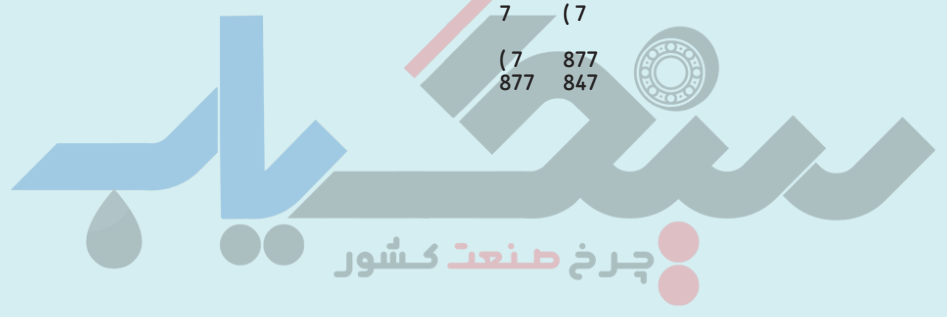

PoMTv		kc3 Lož
<p>d TB I 3 8Ke</p> <p>For(KNNŠnK\ ŠnPrWktŠn(4 (pKRP8 2</p>	$F_{rm} = k_r \left(\frac{v n}{1000} \right)^{2/3} \left(\frac{d_m}{100} \right)^2$	<p>B LOKrŠnh(a ŠNR(-VVV3</p> <p>N LOKrŠnh(LorQNBWOr(-VVVž</p> <p>N_w LOKrŠnh(WOKn(NBWOr(-VVVž</p> <p>] / (-N. (D≤</p> <p>0 MKMl VtŠn(PKMor(-proel M&KLZPs/(pKRP8 02≤</p> <p>F_K KbŠVbKN+e 3</p> <p>F_{Kp} WKbŠVl W(pOrWŠsŠVQ(KbŠVbKN +e ž</p> <p>F_r rKNBVbKN+e 3</p> <p>F_{rW} WŠSVl W(rKNBVbKN+e ž</p> <p>l_r WŠSVl W(bKN(PKMor(-proel M8 tKLZPsž</p> <p>n(rotKtŠnK\špOON(-žVŠ3</p> <p>g(Ql ŠKVnt(NnKWŠ(LOKrŠnh(bKN +e 3</p> <p>g (Ql ŠKVnt(stKtŠ(LOKrŠnh(bKN+e ž</p> <p>Y /Y /Y (MKMl VtŠn(PKMors(-proel M&KLZPs≤</p> <p>≥ oŠVŠMšŠc(Kt(opOrKtŠnh(tOWpOrK8 tl rQ(-VVV ž3</p>
<p>AbTKZKeŠKrrcTnR8 MKpKMEc</p>	<p>BOKrŠhš(Wol ntONon(Kn(KNkptOršVVOQ(on(pVKŠ(sRKPs(a ŠRol (t K-šON(KLI tWont,(F_{Kp}] / (B(N projŠNONtRQ(LOKrŠhš(KrQ(MrrOMV(Wol ntONl</p>	
<p>EqI TWKZPnt8 ecnK3 TMLPKrTnR8 2Ke</p> <p>For(KNNŠnK\ ŠnPrWktŠn(4 (pKRP8 9</p>	$F_K Z_r(O(Q4(g]) (F_r.l. (Y (F_K$ $F_K Z_r(O(Q4(g]) (/ (F_r.l. (Y (F_K$	
<p>EqI TWKZPntŠtKtT8 LPKrtR8Ke</p> <p>For(KNNŠnK\ ŠnPrWktŠn(4 (pKRP8 20</p>	$g ((F_r.l. (Y (F_K$	



m pntMabt m av

>VŠ qSt- 3vžl,S CqStcašmaš- qStcaxtS kCt vŠ,k c,šmšmdc., dSctšmv Cn dS,3 3Šh de

- avŠ h3- Šnvžnc, vždžž CkaVŠ dSctšm tšmv cnh dc.,v
- avŠ Cnš
- avŠ vSc,v
- avŠ ,x dt.žcna

. VŠtŠaš- qStcaxtSv CxavšŠ avŠ qSt- 3vžl,S tcnnš ctS ŠzqŠQŠh CcnaQa Mu

C nB c B dnB md

Mu vŠ,k c,šmšmdc., dSctšmv ctS VŠca vždžžŠh xq aC (7C° 42žš-1

Fm d

j tOO(or(Lrkšš(MkhOš(Mkn(LQl šONKt(tRQškWQ opOrKtŠnh(tOWpOrKtl rOš(Kš(tRQ(LOKrŠnh(ršhš(KnN(LKwš1For(tOWpOrKtl rQŠVŠš(orŠpovWOr(MkhOš/(rOr(to(So(c) gFekl gt/(pKRP8 441

kPKZ

kRO(pOrWŠsŠVQ(opOrKtŠnh(tOWpOrKtl rQšr(e Bi (šOKš(š6 (to. (7C°1 2(ul 5 2žš-1kOWpOrKtl rOšl p(to (7C° 42žš-1Mkn(LQtoVrKtONšr(LrŠrŠpOrŠNš1 kcpŠKw/(tOWpOrKtl rQpOKl s(KrQKt(tRQ šOKVš1

yl LrTKnts

kOWpOrKtl rQŠVŠššr(tRQhrOKšOšl šONŠl šOKVONj x F(šOVŠKŠnŠnh(LKW(LOKrŠhš(KrQ projŠNONš(tKLZP8/(pKRP8 91For(tOWpOrK8 tl rQŠVŠššrOršrOrj x F(hrOKšOš/(rOr(to(g(geuml *žanky(g+ bs + FgKt g/(pKRP8 9•1 v ROnl ššnh(V LrŠKnts(notšl ppšON(Lc j x F(tOWpOrKtl rQŠVŠšššRol V(LQOJKV KtON KMšrNšh(tRQj x F(trKpŠMšRt(MnMDpt(-pKRP8 91ž

nt vw f mvpmmT BnM n v on v mmyrv

>V6 vqSSH tca3mv 3i dV6 proel M&KLZs 3ih3ca5

dV6 rPpPrnMP&pPpe y W6WSncd,Sv c Fx3I cvwSw- SnaCkaV6 vqSSH Cqcd333v kC- c dV6St- c, kC- S CktSkStSnOS dV6 ZB TTrR&pPpe y W6W3c - SOWn3c, ,3 3aV6avW6x,hnCadS SzOSShSh xn,Sw dV6 dSct3imhSv3im cnh dV6 cqg,3ca3cn ctS chcqash kCt V6V6St vqSSHv

uCt chh3Cnc, 3iKt- ca3cn tSkSt dC 4r3ueKp K31 r3ueKy3 enWw 33WpKRP962

:) f e n n- i f i : f u n- w e e f K r : u W i p u k f n i : p b n K W e e

f n f W r K u w : : c p n r f e n p u v K r r : W w e f) K w -R199 f e e W f e f w : : c p n w K r r : W w e f) K w -R19

A W r K u w : : c w f u v b r r e W k p r : K e e f p k e n- W c k : v p u f r r u p r u f K g v f W r K u w : : c w u) : u k p k e : p r o e l M & K L Z p K R P 8 0 4

e : n b w n- w f : W i : f u n- w f : v b u f r r u p r u f K g v f W r K u w : : c f w w i e w : - t W w e n w : : c u) : u k p k e : p r o e l M 8 t K L Z f u b w W k p r u c : n K k e : p k e n- W c k :) u p e n K u) : u n- e e k e : w f -R196 A K u n f k e : T b w f w r f k u u n- i : k e : : n k e : i : f u n- f n W k e : p k e f v e : u v p u f W w k p n f e n) p u f k p n A V e r K 3 u w e B 3 M w p K R P 9 2 e 0 (K S V e d e O m e B 3 M w p K R P 9 2 4 1



Dmv n honv TntMa onv

BM ptoatbv on

>V6 dc,,v CkvC- S dSchT 1 t t w u e w r u p K u b W) u p k e : v e W) f k : w p) k e : i : f u n- -R192 e : c f : b : w p) k e : r u p K u b w p n f u e k W e n k e : p r o e l M & K L Z p K R P 8 0 1 f n W w e p b W i : k p n w W u W e e : n W w e n e n- k p r p n : n k w e n k p w r u p h e e T k p k e : i : f u n-

BnM n v c a Mh neamTnt nnt t n

e : n k e p p) k e : w i : f u n- w f u b w W k p w b r r p u k f w e f) K k p p k f K k e : w e f) K f h e f T k e : e n n : u u e n- w p k w b w k i : f u f n- : W f k e n- k p e f u W w p u f e f T) u p : f k e p k e : u -R18 p K R P 8 9

FR192

hrotrl sTn&g&KZ&gro3 &T&P&KMPs

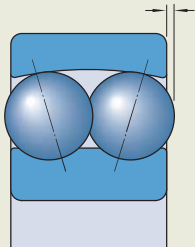

FR199

BPKrTrRs& Ti 3&KpPrPe&orP8 ol ntPe& Ti 3&n&KeKptPr&ZPPvP

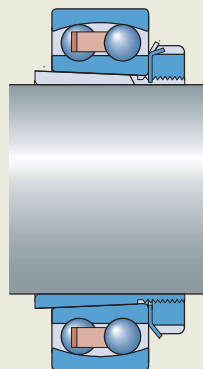

Tn c qc3i vW6ka

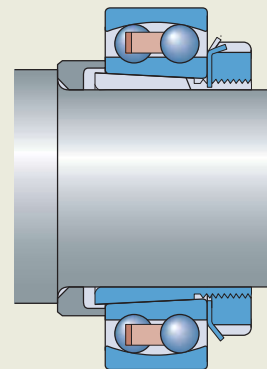

Tn c vaSqSh vW6ka

Apptopt Mamf nM n obv n v

AqqtCqt3e3 Mu dSct3mVcxv3mvtS cLc3
cd,S3i c Lct3æ CkhSv3mvt cnh v3Sv Kct c
y 3S tcnns Ckccqg,3e33nv >V6 hSv3mvt
3QxhS

i N s q,x- - St q3,Cy d,CC Vcxv3mvt
3n(tRO / / (KnN (sOrSs
(Fe y(5KnhONRol s3ihs
(j AF(pV WWOr-pS3ba 3L3M(Rol s3ihs33r
3MR(sRKRPs

ANN33nKv33rWkt3n(KLol t3j xF(LOKr3ih
Rol s3ihs(3 KJKSLV(on33Qkt
[sl 3M3W3Rol s3ihs1](#)

i obnan f nM n v c a MaMptmT f otm

BOKr3ihs(a 3R(KtkpOrONLorQKrQWol ntON
a 3R(Kn(3nOr33rOnM3-3/Lc(l s3ih(onQor33rO
3W3a 3ih(WO3rONs,

98FPP23r3i P3M3K3rKnM33Pel M33n3c3
tl rn3r3kne3a TP23r3i P33l tPr33r3
, -R19 -

O(kRS(WO3rONs(JK3333r(LOKr3ihs(a 3R
e orWkVrkn33vMOKrKnM3-not33r(sOKON
LOkr3ihs3

O(kRO(MOKrKnM3rON M33n(3n(tRO(LOKr3ih
S3l P33nt(a Ron(tRO(ol tOr(r3ih(Mkn(LO
tl rnONOKs3/Ll t(k333r(r3sStKnM3(3
POV(a Ron(33sa 3ONONol t1

3d PKsl r3r3i P33M33l t33r3 tPn3r3knR33
, tKL33l.3.KRP8 4-

63d PKsl r3r3i P33b33r3r3P/l p33tKL33l-

3App23r3i P33x33r3r3P/l p33l Pti oe

For(LOKr3ihs(a 3R(Nfi (WW/lj xF(rONW3
WOn3(l s3ih(tROj xF(Dr3333 p3z O3rON
kRS(3(KR3st/rO33L3(KnN3k33r(WO3rONto
NO3rW33rO(kpprop33r333nOr33rOnM3-3
ANN33nKv33rWkt3n(3 KJKSLV(on33Q
kt(s1 [3M3W33333 p1](#)

For(KN33nKv33rWkt3n(KLol t(tRO3
Wol nt3ih(WO3rONs/(rOP3rto/l Cyn3n h3eu
(n wd (3 e ker 33W3hCu3/(pKRP8 26/or(tRO
) Ov h3eu3n 1 e(n33nenk3 3enV3CC-1

i obnan

i obnan f nM n v c a Mhg nTt hM f otm

i OP3rto/l Cyn3n h3eu3n wd (3 e k33nW3ke0
hCu3/(pKRP8 291

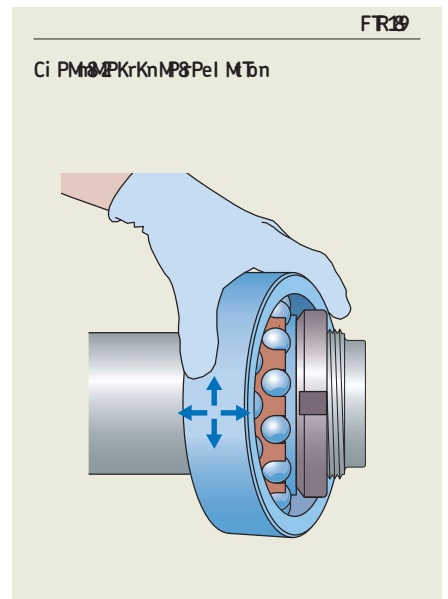
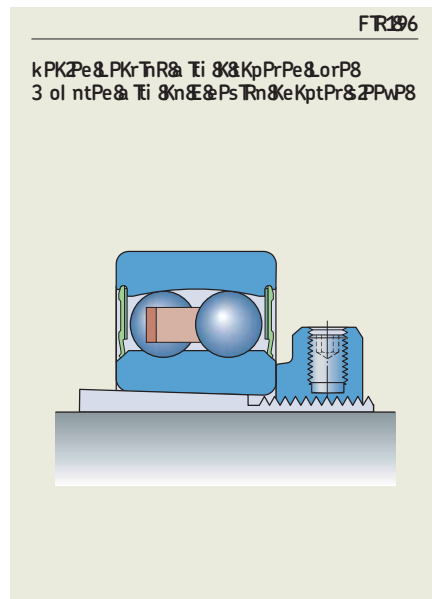
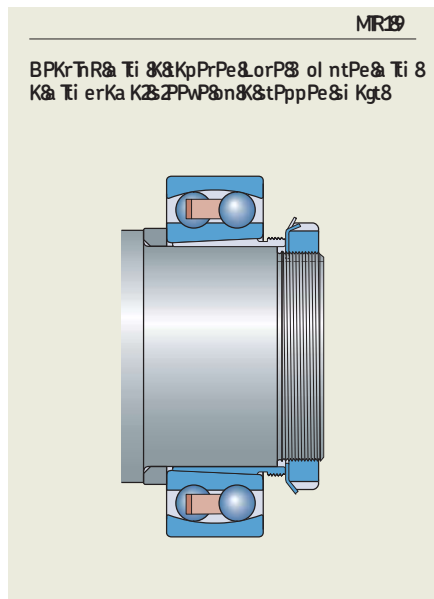

s vĹ6 cr 4gbġ 7va6 7 g 7ġn79 Tġ T6gv7ġa f 70 g bġr6v64 Tov6

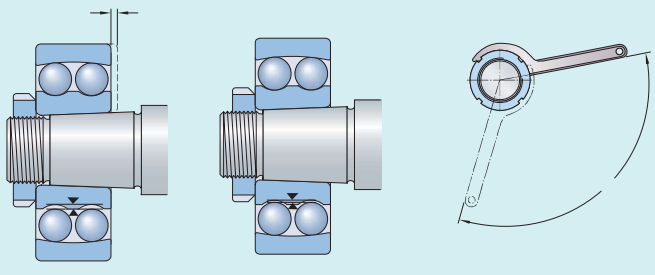

Bov6 4ġ 6b6v h	Ai 7ġ 4vĹ6 cr v 1	kom nc bb70b6n79 gn9 6 2
11	11	
	22 22 22	



2
2

4 Dc egQ3 Daα5° hKt ae5 dF m5αD3
 - α5 Qc53 eg@5b ga5 egQ3 DaQ Da bDQ3 bc55Qαg db go3 85o5agQgFFQ gcDb - α5T ga5 dS5 db53 gb 8d.35Qo5 eg@5b DoQ gb. c. b
 k- i y 7ġp 7nġbġ 7fi 7n 7n6 N bġNvbġ) 7px-bpġ 7ġp 7firġN NQkvMmys 7k 7((rġck7) fibRġntd rġm 7firġk 7((rġm 7ġn79) 7k rġwġx